



BL7066 LED 10W, 15W

Applications

LED accent light with multiple beam patterns and retractable shrouds, 360° rotatable and 180° tiltable, ideally suited for accent lighting. Miniature size, unobtrusive appearance. NPT 0.5" stem with choices of mounting accessories allow installation on hard surfaces, lawns and trees. TRIAC dimming standard.

Dimensions

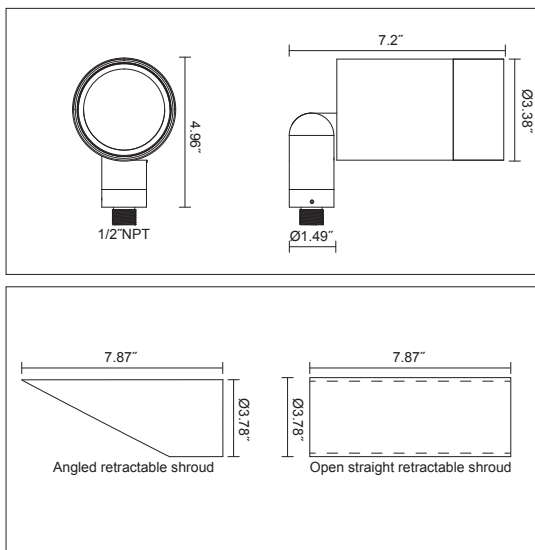

Ordering Guide:

Example: BL7066 - C10 - 4 - 20 - 80 - NS - B - H

Series	Power	CCT	Beam angle	Ra	Shroud	Housing Color	Accessories
BL7066	C10: COB 10W C15: COB 15W	3: 3000K 4: 4000K	20: 20° 40: 40° 60: 60° 4523: H45°xV24°	80: Ra80	NS: No shroud AS: Angled retractable shroud OS: Open straight retractable shroud	B: Black RAL9011 W: White RAL9016 G: Gray RAL7012 Z: Mineral bronze S: Silver RAL9006	KA: Mounting bracket A KB: Mounting bracket B KC: Mounting bracket C J: Junction Box S: Ground Stake P: Tree strap H: Honeycomb Louver M: Marine ambient corrosion resistance (TRIAC dimming standard)

Specifications

Housing	Die-cast aluminum
Gasket	Silicone rubber
Front Cover	Tempered Glass
LED Optic	Polycarbonate Lens
Surface Finish	AkzoNobel powder coating
Driver Type	Constant current, TRIAC dimming standard
Input Voltage	120V/AC
Ambient Temperature	-20°C~45°C
Ingress Protection	IP65
Certifications	ETL US Intertek

Options and Accessories

